

4



FALCON SEMI-BATCH (SB) CONCENTRATORS

APPLICATIONS

- Recovery of gold, silver and platinum group metals
- Recovery of gold from cyclone feed, underflow or overflow within the grinding circuit
- Recovery of gold in alluvial gold operations
- Recovery of gold from aggregate plants

KEY ADVANTAGES

- Unit capacities up to 400 t/h
- The variable frequency drive (VFD) and a dynamic braking system are used to greatly reduce offline time for concentrate flushing
- Flat lid modular design increases wear life and reduces downtime as well as maintenance costs
- Upgraded standard fluidization control results in a higher degree of machine management
- High G forces (highest in the mineral processing industry) allow for higher efficiency and the recovery of very fine material
- Reduced water consumption as only the pertinent collection zone section of the bowl is fluidized
- Greater than 95% mechanical availability, extremely low operating costs
- Fully automated, "one touch" operation that provides the least amount of offline time and highest possible concentrate security

COARSE AND FINE PRECIOUS METAL RECOVERY

Falcon SB Concentrators are known as "Semi-Batch" because they continually accept feed during the run cycle, but only produce concentrate during the periodic rinse cycles. Run times span from five minutes to several hours, depending on the application. Rinse times are generally less than a minute as Falcon Concentrators utilize a dynamic braking system to quickly slow the bowl down, rinse out the concentrate, and then return to full operational speed. Equipped with a variable frequency drive, this gravity concentrator can operate anywhere from 50 to 200 G's.

The typical application for a Falcon SB Concentrator is recovering liberated precious metals (Au, Ag, Pt, etc.) within a grinding circuit. When installed in this type of circuit, Sepro often recommends that the gravity concentrator be placed on cyclone feed, rather than cyclone underflow to generate higher recoveries. Outside of grinding circuits, Falcon SB Concentrators are also used for precious metal separation from aggregate or placer deposits. The target mineral will usually be in extremely low concentration (grams per tonne) and a very high upgrade is desired (up to 10,000x).

Reliable test work can lead you to the right concentrator for your application. Sepro operates laboratory facilities, which generate decisive data for scale up to commercial operation.

FALCON SEMI-BATCH (SB) CONCENTRATORS

SPECIFICATIONS

| MODEL | | L40 | SB400 | SB750 | SB1350 | SB2500 | SB5200 | |
|--------------------------------------|--------------------|------------|----------|----------|----------|-----------|-----------|------|
| RECOMMENDED SOLIDS CAPACITY* | t/h | 0 - 0.25 | 1 - 15 | 10 - 80 | 50 - 150 | 100 - 250 | 200 - 400 | |
| MAX SLURRY CAPACITY | m ³ /hr | 2.3 | 30 | 100 | 200 | 300 | 450 | |
| CONCENTRATING SURFACE AREA | m ² | 0.03 | 0.21 | 0.46 | 1.08 | 2.14 | 3.37 | |
| G-FORCE RANGE | upper | 200 | 150 | 200 | 200 | 200 | 200 | |
| | lower | 50 | 100 | 50 | 50 | 50 | 50 | |
| MACHINE WEIGHT | kg | 35 | 485 | 1 250 | 2 900 | 4 560 | 6 900 | |
| MOTOR POWER | kW (HP) | 0.4 (0.5) | 3.7(5.0) | 7.5 (10) | 18 (25) | 45 (60) | 75 (100) | |
| PROCESS WATER CONSUMPTION | m ³ /hr | 0.24 - 1.2 | 3 - 5 | 8 - 12 | 12 - 20 | 15 - 28 | 25 - 35 | |
| WATER SUPPLY PRESSURE | bar | 2 - 3 | 2 - 3 | 2 - 3 | 2 - 3 | 2 - 3 | 2 - 3 | |
| RECOMMENDED MAXFEED PARTICLE SIZE | mm | 1.0 | 2.0 | 2.0 | 2.0 | 2.0 | 2.0 | |
| ABSOLUTE MAXIMUM FEED PARTICLE SIZE* | mm | 1.5 | 2.5 | 4.0 | 4.0 | 4.0 | 4.0 | |
| MAXIMUM FEED PERCENT SOLIDS* | % | 55 - 70 | 65 | 55 - 70 | 55 - 70 | 55 - 70 | 55 - 70 | |
| CONCENTRATE SLURRY FLUSH VOLUME* | litre | 1 | 25 | 100 | 150 | 250 | 350 | |
| CONCENTRATE SOLIDS FLUSH VOLUME* | cm ³ | 120 | 1 230 | 5 275 | 12 425 | 18 750 | 24 050 | |
| DIMENSIONS | WIDTH | m | 0.49 | 1.02 | 1.71 | 2.24 | 2.67 | 3.19 |
| | LENGTH | m | 0.31 | 1.00 | 1.44 | 1.90 | 2.00 | 2.32 |
| | HEIGHT | m | 0.51 | 1.43 | 1.50 | 2.07 | 2.27 | 2.73 |

*Denotes application specific parameter, consult manufacturer.

Note: Specifications are subject to change without notice. Equipment may not operate or achieve best performance under maximum capacities.

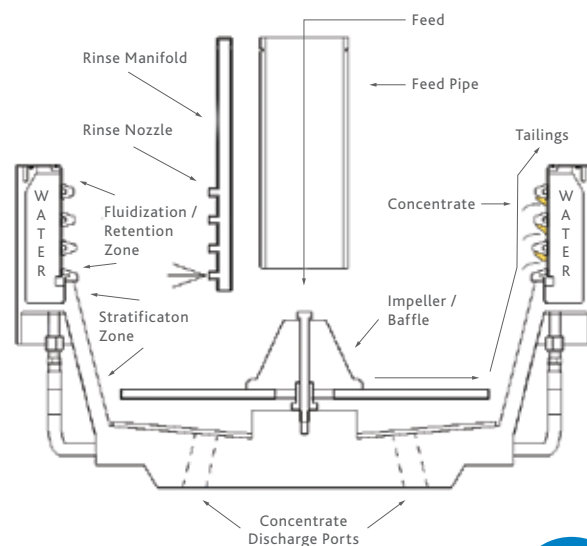
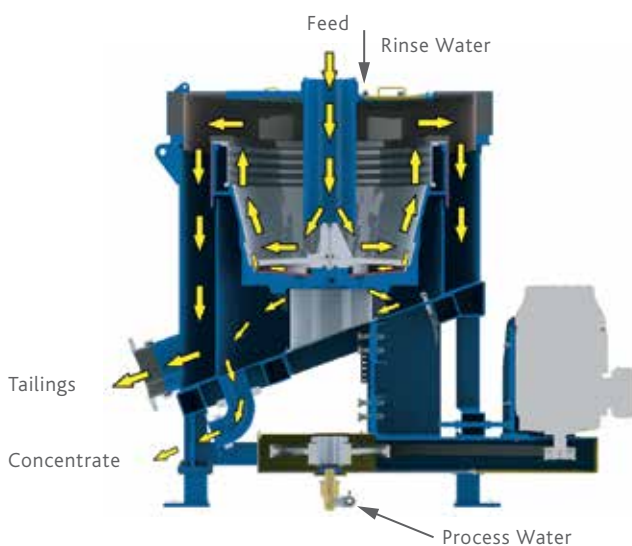

Sepro Mineral Systems Corp.

9850 201 Street, Langley, British Columbia, Canada V1M 4A3

Office: +[1] 604.888.5568 • Fax: +[1] 604.888.5521 • Toll free: +[1] 800.990.5568 North America

sepro@seprosystems.com • www.seprosystems.com

